

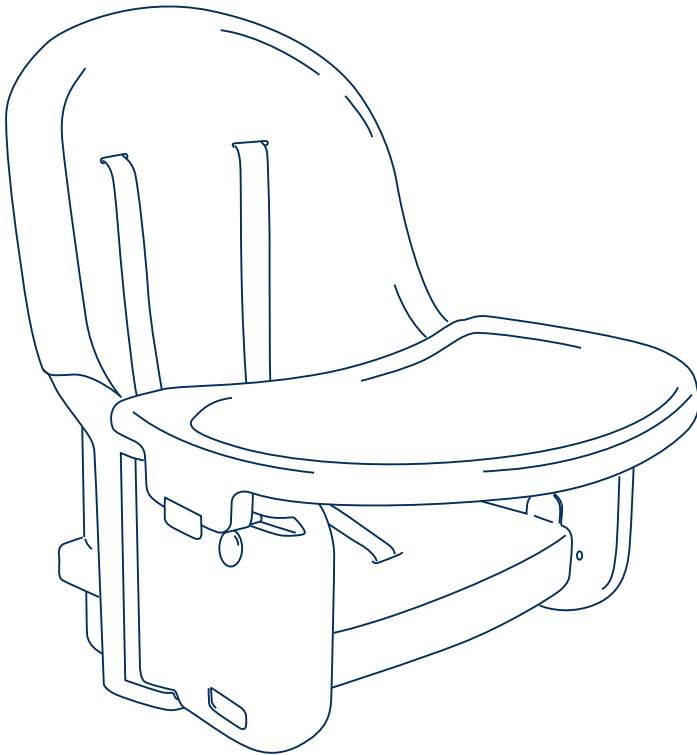

deluxe folding

booster seat with cushion

user guide



Important! Keep for future reference

introduction

This booster seat allows your child to sit with you whenever using a table, by securing the booster on a suitable chair*, and when not in use, can be folded compactly for storage. A generously padded, washable cover is included for your child's comfort.

The tray is detachable to allow the seat to be used with or without the tray.

Suitable for children who can sit unaided (around six to nine months) to around 4 years.

* Refer to the safety notes section on page 9 for information on suitable types of chairs.

parts checklist

Note: The padded cover and harness are pre-fitted to the booster, but the booster can be used with or without the cover. The cover is shown separately below to help you familiarise yourself with the product.

fig 1a



frame & harness

fig 1b

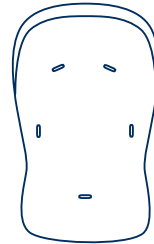

padded cover

fig 1c



tray

fig 1d



lower securing strap

preparation for use

fig 2

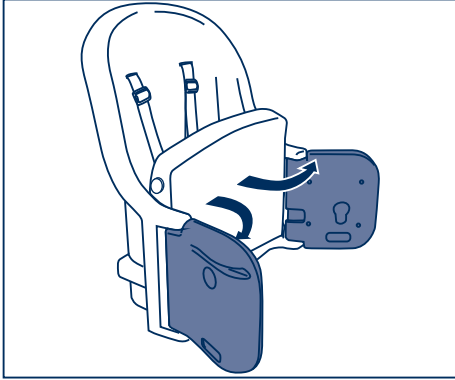

Swing the side panels outwards as shown.

fig 3

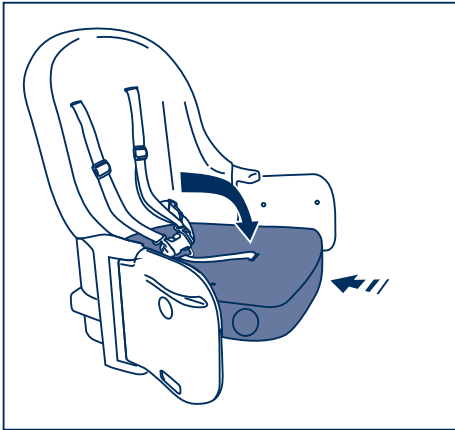

Lower the front edge of the seat and push towards the backrest.

fig 4

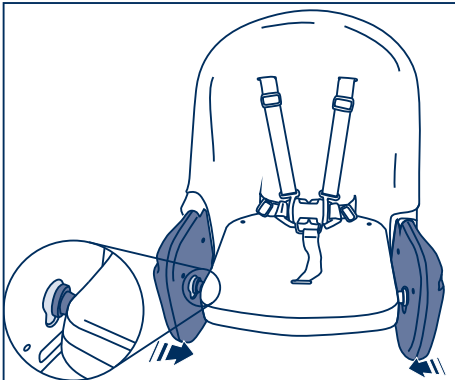

Locate the studs at each side of the seat in the keyhole shaped sockets on the side panels, then ...

preparation for use

fig 5

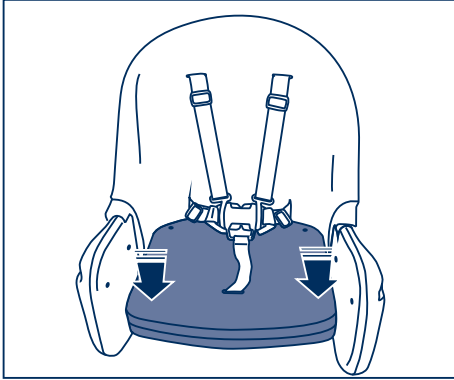

... press the seat firmly downwards until the studs click securely into place.

Check they are secure by pulling upwards on the front edge of the seat.

fig 6

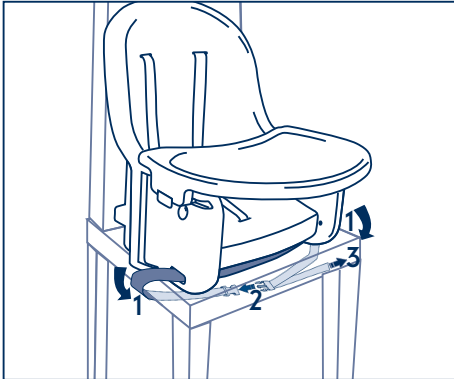

Position the booster on the chair*.

Pass the lower securing strap through the slots in both side panels, wrap the strap underneath the chair (1), and fasten the buckle (2).

Tighten the strap by pulling on the end of the strap (3) to remove any slack. On cushioned seats, press firmly down on the booster seat to compress the cushion while tightening the strap.

* Refer to safety notes on page 9 for information on suitable types of chairs.

fig 7

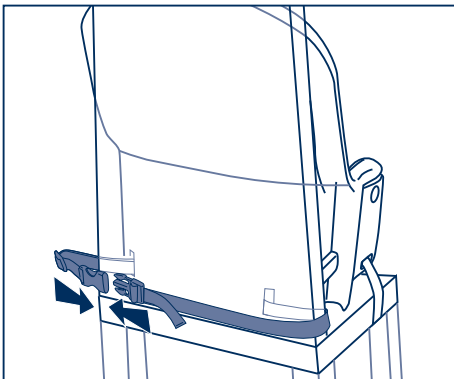

To avoid damage to the chair or buckle, both ends of the rear securing strap are adjustable so the buckle position can be positioned away from the corners of the chair.

Tighten the securing strap by pulling on the end of the strap to remove any slack.

Always check that the booster is secure and stable before putting your child in.

harness

fig 8

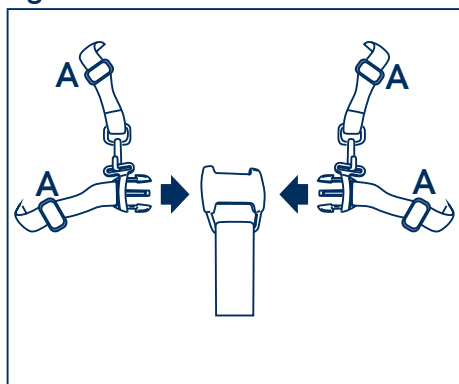

To fasten
Insert both fasteners securely into the clasp.
Adjust each strap with adjusters A.

fig 9

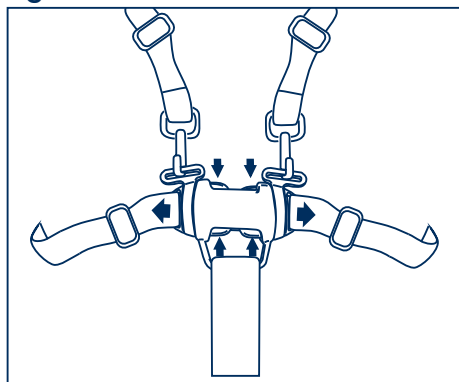

To release
Press the fastener prongs and pull apart.
Your child should be securely harnessed at all times and should never be left unattended, even for short periods.

tray

fig 10

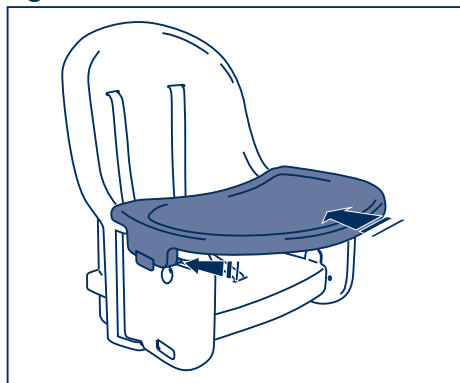

The booster can be used with or without its tray.

To use, slide the tray into the grooves in the side panels.

fig 11

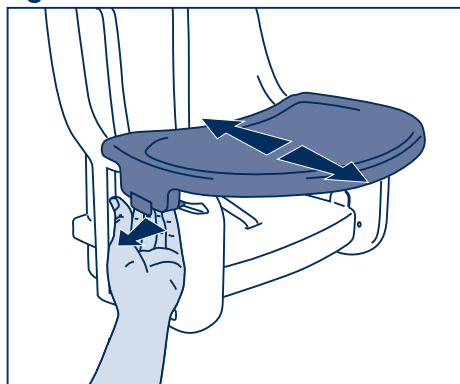

The position of the tray can be adjusted by releasing the clips on both sides of the tray, moving to the desired position, and releasing.

Always check the tray is secure before use.

after use

folding for transportation or storage

fig 12

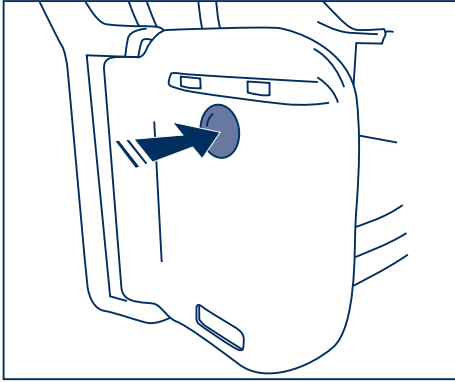

Remove the tray.

Press and hold the button on the outside of each side panel, and ...

fig 13

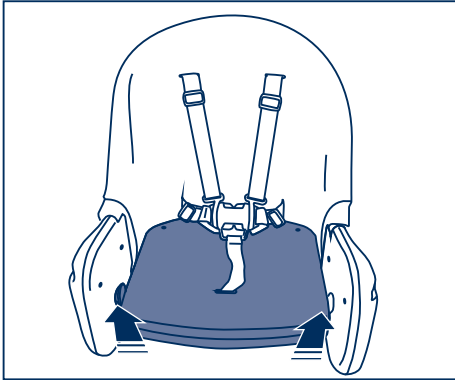

lift the studs at the sides of the seat out of the keyhole shaped slots in the side panels.

fig 14

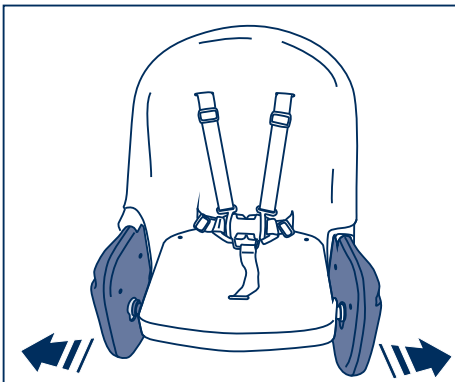

Swing the side panels outwards.

after use

fig 15

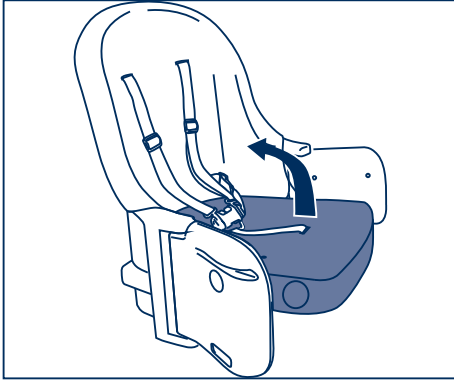

Pull the front of the seat forwards slightly and lift the front edge of the seat so it touches the backrest.

fig 16

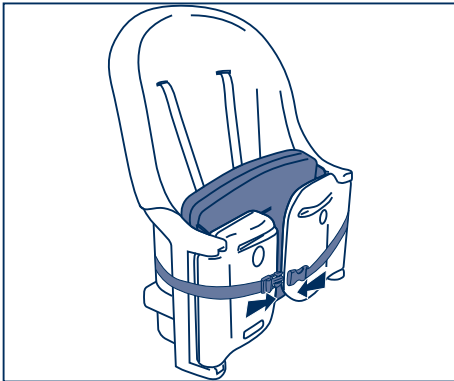

Swing the side panels inwards.

Use the lower securing strap to keep the booster folded by fastening it around the booster.

care of your product

strap & cover removal

fig 17

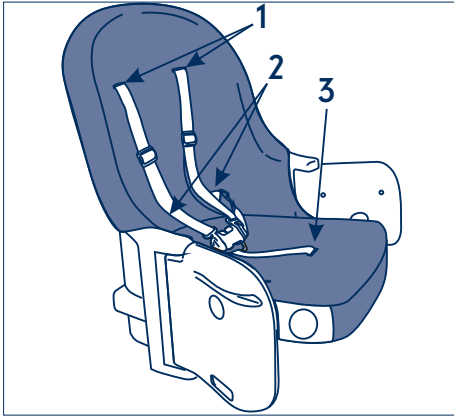

The padded cover and harness straps can be removed for machine washing at up to 40°C.

The shoulder straps (1), waist straps (2) and crutch strap (3) are removed as shown in figure 18.

To remove the cover, release the side panels (figures 12 to 14), lift the seat upwards (figure 15), and carefully lift the cover off the seat (figure 19).

fig 18

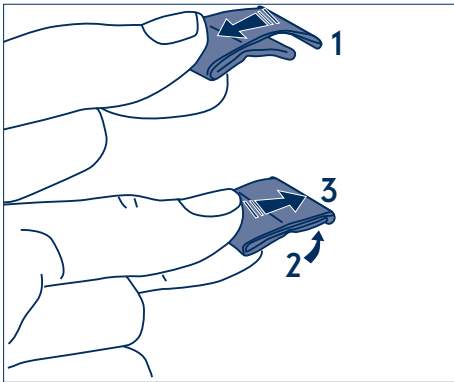

1. Pull the strap away from the slot.

2. Pinch the end of the strap to flatten.

3. Pass the strap through the slot.

When re-fitting, ensure the ends open out again so they cannot accidentally pull through the slots.

fig 19

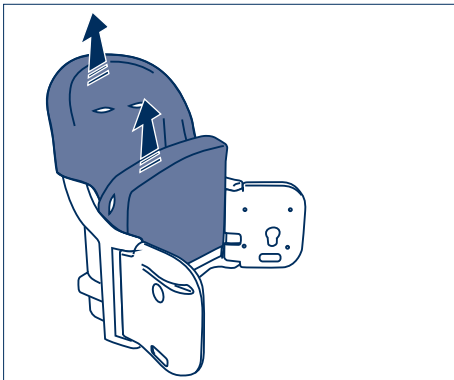

Once the harness straps have been removed, raise the front of the seat and lift the cover off.

When re-fitting the cover, reverse the steps shown in figures 17, 18 & 19.

care of your product

- The booster and tray can be cleaned by sponging with warm water and a mild detergent. A mild disinfectant may be used.
- Stubborn marks may be removed with a non-abrasive cream cleaner. Never clean with abrasive, ammonia based, bleach based or spirit type cleaners.
- The cover and harness straps can be machine washed at 40°C and tumble dried at low heat.
- Periodically check for damage, including internally, and discontinue use if any part is damaged or broken.

safety notes

fig 20

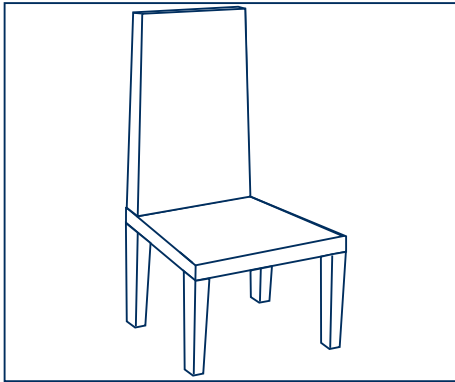

The recommended type of chair is as shown left, with four legs, a high backrest, and firm seat. If the chair has a cushioned seat, check the securing straps periodically to ensure they have not loosened.

Do not use the booster on a table top, stool, swivel chair, folding chair or any other type of chair that the booster cannot be firmly secured to.

- **WARNING! YOUR CHILD'S SAFETY IS YOUR RESPONSIBILITY.**
- The booster must be fully secured on the seat before placing a child inside.
- Ensure the harness is correctly fitted and adjusted at all times.
- When using the booster at a table, ensure the child cannot push against the table or another chair, and tip the booster and chair over.
- Keep away from trailing cords flexes, electric irons, ornaments and other such hazards.
- Do not use close to any source of heat.
- Never use the booster in a vehicle as a car seat.
- Do not move the booster or chair with the child inside.
- Do not use if any part is broken, damaged or missing.
- If the booster is used by someone unfamiliar with it e.g. grandparents always show them how it is used.
- Never leave your child unattended, even for the shortest time.